



COCHRAN

Highlander Package Hot-Water Boiler



ENERGY SOLUTIONS WORLDWIDE

The BIB Cochran Highlander is a compact, cost effective hot water boiler, built to BIB Cochran's high standards and featuring the low NOx, low noise combustion equipment as standard. Featuring a full wet back design for maximum efficiency, the compact design and small floor area taken by the boiler makes it ideal for a wide range of applications such as laundries, hotels and small to medium sized manufacturing.

Ratings:

From 293 kW to 2930 kW

(1.0x10⁶ BTU/hr to 10x10⁶ BTU/hr)

(or 252 10³kCal/hr to 2520 kCal/hr)

Standard Working Pressure:

4.5 BAR

Ratings below 293kW are available upon request

Working pressures up to 8 BAR are available upon request

Stainless Steel condensing economisers are available upon request

Design concept:

- 3-pass wetback reverse flame
- Complies with Gas Appliance Directive for boilers operating below 105 °C
- Products are CE marked
- Robust design and construction for long life
- Total package incorporates combustion equipment, control panel, all necessary valves and fittings

Quality:

- Procedures are third party audited to ISO 9001
- Pressure tested and inspected
- Compliance to EN303

Efficiencies:

- Typical 90% nett gas firing*
- Typical 91% nett oil firing*
- Complying with Efficiency of Hot Water Boilers directive

* Efficiencies based upon
N.C.V. of 34828 kJ/m³ (gas)
N.C.V. of 35863 kJ/l (oil)

Full range of support services available including:

- Turnkey boilerhouse supply
- Installation and project management
- International commissioning & maintenance service
- Full spares support

BIB COCHRAN : A LIFETIME SOLUTION

REF NO. COC / 0906 / HIGH

BIB Cochran Highlander Package Hot-Water Boiler

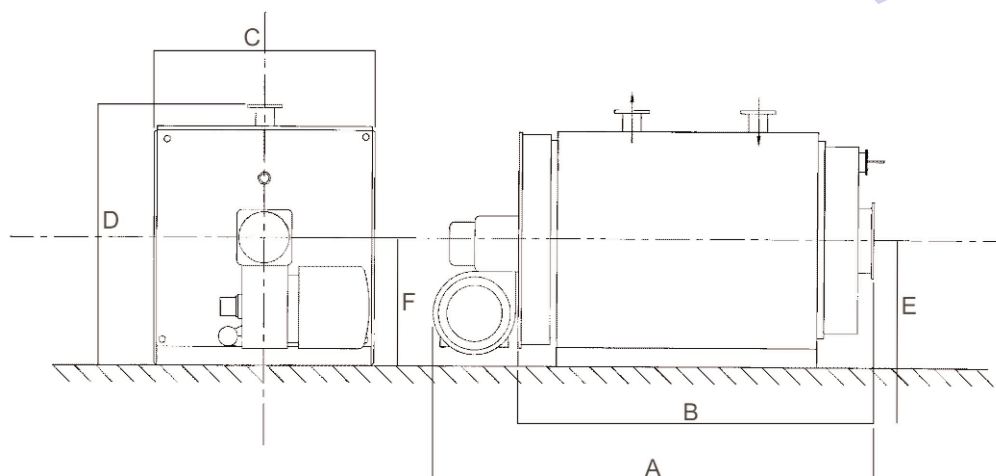

Boiler Ratings	kW	293	366	440	586	732	879	1172	1465	1758	2344	2930
	kCal/h x 10³	252	314	378	504	629	756	1008	1260	1512	2016	2520
	BTU/h x 10⁶	1.00	1.50	1.50	2.00	2.50	3.00	4.00	5.00	6.00	8.00	10.00
Dimensions	A mm	2460	2605	2831	3132	3382	3979	4014	4275	4606	4626	5155
	B mm	1665	1810	2036	2247	2497	2910	2945	3206	3525	3545	3915
	C mm	1060	1090	1150	1150	1370	1370	1520	1605	1730	1865	2020
	D mm	1037	1097	1197	1197	1347	1447	1557	1612	1847	1882	2047
	E mm	490	530	600	600	650	740	770	797	950	938	1035
	F mm	470	510	580	580	631	720	750	777	930	918	1015
	Recommended Chimney Dia mm	150	150	200	200	250	300	300	300	350	400	450
Safety Valve Exhaust Dia. mm	35	35	50	50	50	50	80	80	100	125	125	
Drain Valve Dia. mm	20	20	20	20	20	20	20	40	40	40	40	
Flow Connection Dia. mm	65	65	80	80	100	100	125	125	150	150	200	
Return Connection Dia. mm	65	65	80	80	100	100	125	125	150	150	200	
Fuel Consumption (Oil) l/h	32.6	41.0	49.4	65.7	83.3	99.6	133.1	167.1	199.6	264.6	331.4	
Fuel Consumption (Gas) m³/h	34.0	42.7	51.7	68.5	85.8	104.2	138.9	174.6	208.8	277.3	347.6	
Boiler Weight-Empty kg	655	855	1075	1210	1710	2085	2510	2930	3840	4605	5535	
Boiler Weight-Full of Water kg	937	1160	1456	1657	2551	3027	3871	4502	6243	7433	8756	

Notes

- 1 Oil Fuel Consumption based on Class D: BS2869 N.C.V.35863 kJ/l (15422 BTU/l)
- 2 Gas Fuel Consumption based on Gas N.C.V.34828 kJ/m³ (935 BTU/Ft³)
- 3 All Dimensions and weights are approximate only based upon boiler working pressure of 4.5 Bar g
- 4 Fuel Consumption based on boiler flow temperature of 77°C and working pressure of 4.5 Bar g



BIB Cochran Limited
Newbie Works, Annan,
Dumfries & Galloway,
Scotland, UK DG12 5QU

BIB Cochran Limited
First Floor, 105 Sadler Road,
Doddington Road,
Lincoln, UK LN6 3RS

Tel: +44 (0) 1461 202111
Fax: +44 (0) 1461 205511

Tel: +44 (0) 1522 510510
Fax: +44 (0) 1522 509837

A BIB Group Plc Company

Whilst this information is given in good faith no warranty or representation is given concerning such information which must not be taken as establishing any contractual or other commitment binding upon BIB Cochran Limited or any of its subsidiary associated companies.

Email: enquiries@bibcochran.com
www.bibcochran.com